

Title 35: Environmental Protection

Subtitle E: Agriculture Related Pollution

Chapter II: Environmental Protection Agency

PART 570 DESIGN AND MAINTENANCE CRITERIA REGARDING RUNOFF FIELD APPLICATIONS SYSTEMS

SUBPART A: INTRODUCTION

Section 570.101 Purpose

The intent of this document is to present design and maintenance criteria for run-off field application systems (commonly called vegetative filter systems). These relatively inexpensive systems can be effectively utilized to prevent feedlot run-off generated by small livestock management facilities from polluting streams, rivers, and other waters. Small livestock management operations typically do not have the economic resources necessary to control their feedlot runoff with expensive lagoon-type zero-discharge systems. The vast majority of livestock management operations in Illinois are relatively small and, therefore, these criteria add to currently available procedures of preventing water pollution from livestock management facilities.

Runoff field applications systems need attentive maintenance to function properly. Consistent failure on the part of the operator to maintain a runoff field application system in good operational condition could result in violations of the Act and Regulations. Improper maintenance may also result in the facility meeting the criteria set forth in Rule 203 of Chapter 5. Under Rule 203, the Agency may require any animal-feeding operation discharging pollutants through a man-made device to obtain a National Pollutant Discharge Elimination System (NPDES) permit on a case-by-case determination considering primarily the amount of wastes reaching navigable waters.

Section 570.102 Definitions

Except as hereinafter stated, and unless a different meaning of the term is clear from its context, the definitions of terms used in this document shall be the same as those used in the Environmental Protection Act and Illinois Pollution Control Board regulations, Chapter 3 - Water Pollution (Title 35, Subtitle C, Chapter 1) and Chapter 5 - Livestock Wastes:

“Distribution Manifold” - A device designed, constructed and maintained to provide uniform sheet flow of settling basin effluent across the width of a runoff field application area.

“Effluent Transport System (ETS)” - A non-perforated pipe or other device designed, constructed, and maintained to transport settling basin effluent to a junction box and distribution manifold.

“Field Application Area (FAA)” - A vegetated area designed, constructed, and maintained to remove sediment, organic matter, and other pollutants from livestock management facility runoff by settling, dilution, absorption, adsorption, infiltration, assimilation, and other processes.

“Junction Box” - A device designed, constructed, and maintained to dissipate the energy of the anticipated hydraulic jump from the effluent transport system discharge and to proportionally split the flow to the distribution manifold(s).

“Livestock Waste”-Livestock excreta and associated feed losses; bedding; wash waters; sprinkling waters from livestock cooling; solids removed from settling basins, lagoons, or holding ponds; precipitation polluted by falling on or flowing onto an animal feeding operation; and other materials polluted by livestock.

“Runoff Field Application System” - Those collective constructions or devices, except sewers, used to collect, pump, settle, store, and land apply feedlot runoff which include, but are not limited to, settling basin, effluent transport system, junction box, distribution manifold, and field application area.

“Settling Basin” - A basin designed, constructed, and maintained to remove settle able solids in feedlot runoff by gravity.

“SI” - Soil Infiltration rate (inches per hour).

“VR” - volume of feedlot runoff to be infiltrated by the field application area (cubic feet).

“QF” - Design flow rate (gallons per minute) over the field application area at 1/2 inch depth of flow for a 2 hour contact time.

SUBPART B: DESIGN CRITERIA

Section 570.201 Runoff Field Application System General Design Criteria

Designing an acceptable runoff field application system shall involve:

Meeting the Conditions for System Utilization.

Evaluating the Planning Considerations.

Meeting the Component Design Criteria.

Meeting the Specifications for Vegetation Establishment.

Providing the operator with Operation and Maintenance Criteria at least equivalent to those contained herein, however, with consideration given to the particular circumstances of each system.

Section 570.202 Conditions for System Utilization

Runoff field application systems shall not be constructed or operated at a livestock management facility unless the following conditions are satisfied:

The livestock management facility confines less than or equal to 300 animal units, as animal unit is defined in Chapter 5 - Livestock Wastes Regulations.

No NPDES permit is required for the facility or is currently issued to the facility, based upon the criteria set forth in Rule 203 of Chapter 5. The Agency will make this determination for the operator.

Sufficient land area with characteristics capable of meeting the design and maintenance criteria for runoff field application systems, as determined in accordance with Section 570.204(e) and Appendix E, exists or can be provided by reasonable means.

The runoff field application system is maintained in good operational condition as provided in Section 570.206.

Section 570.203 Planning Considerations

The following shall be evaluated in planning a runoff field application system:

Slopes and soil material, vegetative species, and time of year for proper establishment of vegetation. Also consider the necessity for irrigation of the field application area, visual aspects, and other special needs.

Location of settling basin.

Adequate drainage to insure satisfactory performance.

Provisions for preventing or designing for continuous or daily discharge of liquid waste to the field application area (e.g., provide temporary storage tanks for milking parlor wastewaters or provide alternate field application areas).

Provisions to allow harvesting activities without causing design or vegetative damage.

Provisions for excluding roof water and unpolluted surface water from the settling basin and field application area.

The need to mechanically distribute the flow uniformly across the top of the field application area.

Runoff field application systems designed to be located on soils with infiltration rates outside the range of 1.0 to 6.0 inches per hour, or that are otherwise designed or maintained such that the criteria contained herein are not satisfied, shall be considered innovative designs subject to Section 570.207.

Section 570.204 Component Design Criteria

Settling Basin

Basin volume shall be 4.5 cubic feet per 100 square feet of area contributing runoff plus an additional 10% volume safety factor.

Ramp slope shall not be steeper than 12:1 (H:V), with 15:1 being preferred.

Basin depth shall be 2 to 4 feet.

Settling basins located where groundwater tables rise to within 2 feet of the surface shall be provided with foundation drainage.

The settling basin riser pipe should be 18 to 24 inches in diameter with vertical slots 1 inch by 4 inches high spaced at 1208 intervals around the pipe. There should be 6 slots per foot of height with the bottom row of slots even with the settling basin floor. To avoid excess clogging, offset or locate the riser pipe as far as practicable from the inlet of the settling basin and attach 3/4 inch mesh expanded metal screen cover over the top of the riser pipe.

Provide a 3/4 inch mesh expanded metal screen ahead of the riser pipe so that all runoff entering the riser pipe must first cross the screen. Refer to Appendix I for a diagram.

The settling basin ramp, floor, end-wall, and side-walls should be designed, constructed, and maintained to withstand normal operation practices involving power machinery.

Effluent Transport System

Pressurized effluent transport systems shall be designed by normal engineering hydraulic considerations including but not limited to static head, friction losses, flow velocity, and pipe diameter.

Gravity flow effluent transport systems may be designed as pipes flowing full or as open channels. Design velocity shall be 2 feet per second or greater to prevent solids deposition. Minimum pipe capacity shall equal or exceed the design flow rate (QF) over the field application area. The design feedlot runoff volume (VR) shall be calculated by Appendix B. Design flow rate (QF) can be obtained from Appendix G.

Closed pipes used for effluent transport systems shall be provided with some means of cleaning by rodding or flushing.

Junction Box

A junction box shall be provided at the intersection of the effluent transport system and distribution manifold to dissipate the energy of the anticipated hydraulic jump from the effluent transport system discharge and to proportionally split the flow to the distribution manifold(s).

The recommended junction box design specifications are provided in Appendix H.

The junction box should be provided with a removable cover to allow entry for maintenance and prevent entry of objects that would interfere with the operation of the runoff field application system.

Distribution Manifold

Pressurized distribution manifolds shall be designed by normal engineering considerations including but not limited to static head, friction losses, flow velocity, and pipe diameter.

Gravity flow distribution manifolds shall be less than 50 feet long each and at least 2 feet shorter than the width of the field application area.

The following must be considered in the distribution manifold design:

- Construction material
- Length
- Capacity
- Slope (level)
- Solids removal and cleaning
- Providing uniform sheet flow
 - Effluent transport system connection point
 - Capped ends
 - Orifice or V-notch weir design and spacing
 - Splash apron such as pea gravel or concrete
- Location of junction box

Recommended designs of distribution manifolds are provided in Appendix H.

Distribution manifolds must be anchored securely while in operation.

Runoff Field Application Area

The runoff field application area shall be located on gently sloping soils of moderate permeability supporting a heavy stand of grass vegetation and designed to operate by overland flow.

Slopes shall be shaped to cause applied runoff to flow uniformly across the design width for the entire length of the field application area.

The uniform sheet flow shall move downslope through the field application area flow length at a velocity that will provide a minimum contact time of two hours. Appendix E, gives minimum flow lengths needed to provide a contact time of 2 hours at various slopes.

Field application areas shall have a minimum width of 20 feet and a maximum width of 100 feet.

The range of soil infiltration rates specified in the planning considerations to 6.0 inches per hour) insures that the infiltration capacity of the field application area will equal or exceed the volume of feedlot runoff to be infiltrated for the 1 year - 2 hour design rainstorm event. The following equation shall be used for designing the field application area (FAA):

$$FAA = \frac{VR \times 12}{(2 \text{ hours} \times SI) - 1.69}$$

when:
 $1.0 \leq SI \leq 6.0$ inches per hour
FAA in square feet
VR in cubic feet

The procedures for determining VR and SI are provided in Appendix B and C (of this chapter).

Section 570.205 Specifications for Vegetation Establishment

The following specifications shall apply to all runoff field application systems:

All trees, stumps, brush, rocks, and similar materials that can interfere with installing the field application area shall be removed. The materials shall be disposed of in a manner that is consistent with standards for maintaining and improving the quality of the environment and with proper functioning of the field application area.

The field application area shall be shaped to the grade and dimensions shown in the plan or as staked in the field. If necessary, topsoil shall be stockpiled and spread to the required grade and thickness. Excess spoil shall be disposed of in areas where it does not interfere with the required flow characteristics of the field application area.

All areas disturbed during construction shall be vegetated.

To aid in the establishment of vegetation, feedlot runoff shall be prevented from entering the field application area through the use of temporary diversions until vegetation is established to a minimum height of 4 inches and 90 percent ground cover.

Immediately prior to seedbed preparation, apply the following minimum amounts of starter fertilizer per acre:

Nitrogen (N) - 120 pounds of actual nitrogen

Phosphorus (P) - 120 pounds of P_2O_5

Potassium (K) - 120 pounds K_2O

Apply limestone, if necessary, for the species to be grown.

Incorporate the required lime and fertilizer and prepare a firm seedbed to a depth of 3 inches. The seedbed shall be free from clods, stones, or B-43

other debris that might hamper proper seeding.

Select one of the following mixtures and seed according to the rate shown:

Reed canarygrass - 25 lbs./acre

Mixture reed canarygrass and tall fescue - 15 lbs./acre of each species.

Use of species other than canarygrass or tall fescue shall be considered an innovative design.

Apply seed uniformly at a depth of 1/4 to 1/2 inch with a drill (band seed) or cultipacker type seeder or broadcast seed uniformly and cover to a depth of 1/4 to 1/2 inch with a cultipacker or harrow. If a drill or cultipacker seeder is used, seed across the slope or cut channel.

Seeding dates shall be either:

Early spring to May 15.

May 15 to August 1, provided sufficient water is provided for germination and vigorous growth.

August 1 to September 10.

Mulch with clean straw using 2 tons of mulch per acre. The mulch must be uniformly spread over the seeded area.

Anchor the mulch by one of the following methods:

Press it into the soil to a 2 inch depth by using a serrated straight disk or a dull farm disk set straight. Cross the slope perpendicular to the direction of the flow of water, or

Apply a netting on top of the mulch and anchor it with staples.

Section 570.206 Operation and Maintenance Criteria

The following operation and maintenance criteria shall apply as best management practices to all runoff field application systems:

Protect the field application area from damage by farm equipment, traffic and livestock. **LIVESTOCK MUST BE FENCED OUT OF THE RUNOFF FIELD APPLICATION AREA.**

Avoid damaging the field application area with herbicides.

Fertilize the field application area when necessary to establish growth.

Harvest when the forage is at the proper state of maturity for maximum quality feed. No harvesting shall occur after September 15. Use the following guide for cutting stages and minimum cutting height for the species seeded:

Reed canarygrass - cut at early boot stage to heading - minimum cutting height 6 inches.
Reed canarygrass - tall fescue mixture - cut at early boot to heading - minimum cutting height 6 inches.

Repair damage caused by erosion or equipment immediately so the runoff field application system will continue to perform properly. Rills and small channels must be repaired. A shallow furrow on the contour across the field application area can be used to reestablish sheet flow.

To prevent excess organic solids from entering the field application area:

Scrape feedlot regularly; however, do not scrape waste into settling facilities, but place in separate manure stacking area away from settling basin.

Drainage from manure stacking facilities should be directed to settling basin or contained.

Remove solids from the settling basin when 2 to 4 inches accumulate.

Scrape lot frequently during early spring. At least once each 7 days is recommended.

If organic wastes accumulate on the field application area and are damaging vegetation, redistribute wastes.

Remove solids that accumulate in the effluent transport system, junction box, and distribution manifold regularly.

Solids removed from runoff field application system components shall be disposed of pursuant to Technical Policy WPC-2-Design Criteria for Field Application of Livestock Waste.

Periodic soil testing of the field application area is suggested to determine nitrogen, phosphorus, potassium, and pH levels.

Each spring, re-level the distribution manifold and restore the design slope on other pipes.

When vegetation of a kind other than reed canarygrass or tall fescue infests 20% or more of the field application area, the infested area shall be revegetated as provided in Section 570.205.

Section 570.207 Innovative Designs

It is strongly suggested that any operator contemplating use of runoff field application systems not designed, constructed or maintained in accordance with the design criteria contained herein receive PRIOR approval from the Agency for such system. The Agency will approve innovative designs should the operator present clear, cogent and convincing proof that the technique has a reasonable and substantial chance for meeting the requirements of the Act and Regulations, based upon conservative engineering principles. For further information contact the Division of Water Pollution Control - Permit Section in Springfield (217/782-0610), or the Agency regional office in your area.

Examples of innovative designs are:

Settling basin designed at less than 4.5 cubic feet per 100 square feet of drainage area.

Settling channel used instead of settling basin.

Use of terraces for field application area.

Riser pipe designed differently than provided herein.

Use of vegetation other than tall fescue or reed canarygrass.

Greater than 300 animal units on feedlot.

Distribution manifold designed for full pipe flow driven by gravity.

Not providing a junction box.

Application of materials other than feedlot runoff, rainfall, or milking parlor washwaters to the runoff field application system (for example silage leachate, sewage, pesticides, oil, refuse).

Use of field application area smaller than provided herein or with less than 2 hours contact time.

Use of soils on runoff field application area with infiltration rates outside the range of 1.0 to 6.0 inches per hour.

Use of field application area widths greater than 100 feet.

Section 570.APPENDIX A Design Procedure Outlined

Collect Site Specific Data

- Types and Areas (sft) contributing drainage
- Slope of Field Application Area (FAA) - Appendix D
- Soil Infiltration Rate (SI) of FAA - Appendix C

Calculate Runoff Volume and Total Drainage Area Working Table in Appendix B

Settling Basin Design

- 4.5 cft/100 sft of drainage area + 10% extra volume
- Dimensions from Appendix I

Field Application Area Design

- $FAA = (VR \times 12) / ((2 \times SI) - 1.69)$ (square feet)
- Dimensions from Appendix E

Calculate Flow onto Field Application Area

- Flows from Appendix G or
- $Q_f = (.0026) (FAA)$ (gpm)

Effluent Transport System Design

- Recommended Designs from Appendix F

Junction Box Design

- Recommended Design from Appendix H

Distribution Manifold Design

- Recommended Designs from Appendix H

Section 570.APPENDIX B

Table 2 Procedure to Estimate Volume of Feedlot Runoff*

	(A)	X	(B)	=	(C)
Type of Drainage Area	Area (Square feet)		Multiplication Factor (feet)		Runoff Volume (Cubic feet)
Roof			0.1408		
Feedlot					
a. Paved or Concrete			0.0991		
b. Earthen			0.0748		

1. Feedlot Runoff Volume = Total of Column (C) (cubic feet).
2. Milking Parlor Washwater = gallons/day x .936 (cubic feet-per week).
3. Design Runoff Volume (VR) = 1 + 2 (cubic feet). Use VR (cubic feet) for designing field application area.
4. Total area (sum of column A in square feet) divided by 100 is used to design settling basin.
5. To convert Runoff Volume (VR) from units of cubic feet into equivalent units of gallons, multiply cubic feet by 7.481 gallons/cubic feet.

* Multiplication factor corresponds to Q of the U.S.D.A. - S.C.S. runoff equation.
 Storm event (I) is 1-year, 2-hour storm of 1.69 inches.
 Curve numbers (CN) are 100-roof; 95-paved; 91-earthen.
 $S = (1000/CN) - 10$
 $Q = (I 2 0.25)^2 / (I 1 0.85)$

Section 570.APPENDIX C Procedure to Estimate Soil Infiltration Rate

Soil infiltration rate for a runoff field application area can be determined by using:

- 1) Any of three methods given in EPA Process Design Manual - Land Treatment of Municipal Wastewater dated October, 1981; Chapter 3.4 - Infiltration Rate Measurements.
- 2) The following modified cylinder infiltrometer method:

Procedure

Preparing the test site

Drive a rigid, leak-proof container approximately 6 inches into the ground taking care to avoid disturbing the soil as much as possible. This container should be approximately 2 feet long by at least 10 inches wide, and may be of any suitable material. A metal pipe is recommended (see Figure C-1).

Saturation and Swelling of the Soil

Before conducting the test, saturate the soil for at least four hours, but preferably 8 hours, by refilling the container with clean water as needed.

Testing

At the time of the test, adjust the water level to 12 inches above the soil surface. Allow the water level to drop six inches and then commence measuring the drop in water level at 15 minute intervals until the water has infiltrated. Repeat this step.

Recording Results

Record results of all tests as the total minutes required for the last six inches of water to infiltrate (minutes/inch). Average the two tests at each site. For example:

Site 1 - Data Recorded

Min	inch
0	6.0
15	4.5
30	3.5
45	2.5
60	2.0

$$\frac{60 \text{ minutes}}{(6 - 2 \text{ inches})} = \frac{60}{4} = 15 \text{ min/inch}$$

Soil Infiltration Rate

The soil infiltration rate (SI) is calculated at each site:

$$SI = \frac{36}{\text{min/inch}} = \text{inch/hour}$$

Example

$$SI = \frac{36}{15} = 2.4 \text{ inch/hour}$$

Average the soil infiltration rates from each testing site to calculate the SI value for the runoff field application area.

These tests must not be made on frozen ground and include a safety factor in Part E to compensate for inherent inaccuracies in this procedure.

3) Data from a modern U.S.D.A. - S.C.S. soil survey for the county where the runoff field application system will be installed. Use the Table of Engineering Properties - Physical and Chemical Properties for Permeability of the surface soil layer as follows:

Locate the soil name and map symbol for the field application area on the map sheets (example - 386A, Downs).

On the Physical and Chemical Properties Table locate the surface layer permeability rate.

Example

Table 15 — Physical and Chemical Properties of Soils

Soil and map symbol	Depth (inches)	Permeability (in/hr)
386A, 386B	0 - 7	0.6 - 2.0
Downs	7 - 30	0.6 - 2.0
	30 - 60	0.6 - 2.0

At the surface layer (0 - 7 inches for the example) use the average value of the permeability range to obtain SI.

Example

$$SI = \frac{2.0 + 0.6}{2} = 1.3 \text{ inches/hour}$$

Figure C-1: Cylinder Infiltrometer

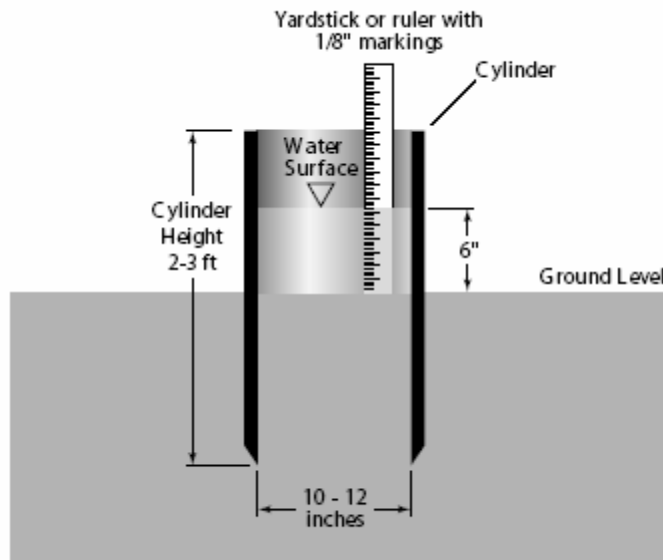

Section 570.APPENDIX D

Procedure to Determine Slopes

Slope must be determined at the site of the runoff field application area to use Appendix E. Many methods are available to determine slope but all methods are based on the fact:

$$\text{Slope} = \frac{\text{change in elevation}}{\text{change in distance}} = \frac{\text{rise}}{\text{run}} = \frac{\Delta y}{\Delta x}$$

where Δ means "the change in"

The following procedure can be used to determine slope.

Obtain a 40 foot length of string or wire with a 25 foot section marked off (if you use nylon, measure the 25 feet with a steel tape because nylon stretches when pulled taut); carpenter's line level from a hardware store; a stake; a rod about 8 feet long (an 8 ft. 2 x 4 works well); a tape measure; a notebook and an assistant.

Set up your notes as follows:

Site	run (ft)	rise (ft)
1	0	0
1-2	25	
2-3	25	
3-4	25	
etc.		

Refer to Figure D-1.

Stake one end of the string at point 1 and attach the other end to the rod so that there is 25 feet between the stake and rod, and the string can slide up and down the rod. With the string taut, level the string in the center using the line level and record the rise at point 2 in your notes by measuring the string height at the rod.

Repeat step 3 all the way down the field and calculate the slope by:

$$\text{Slope} = \frac{A(100)}{B} \quad (\% \text{ or ft}/100\text{ft})$$

Use the % slope for Appendix E.

Figure D-1: Field set-up for determining slope

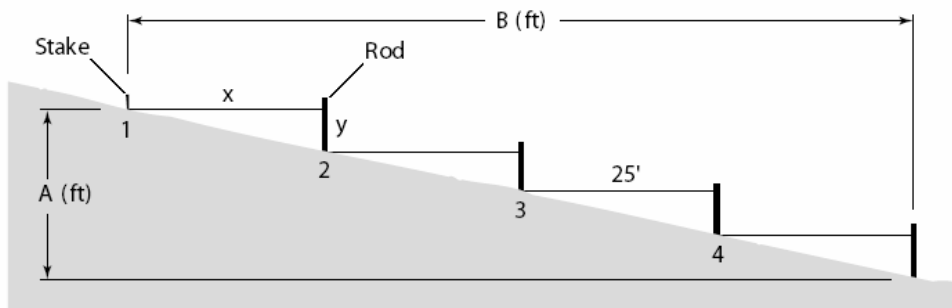

Section 570.APPENDIX E Tables to Determine Dimensions of Field Application Areas

How to Use Table 3

Slope %	0.5	0.7	1.0	1.5	2.0	3.0	4.0
Length (ft)	300	375	425	525	600	750	800
Width (ft)	20	25	30	35	40	45	50

- ① Enter at slope of field application area from Appendix D.
- ② Read down column and find corresponding length of field application area.
- ③ Continue down column stopping at area closest to that previously calculated for your site.
- ④ Read left to find width of field application area.

TABLE 3
Runoff Field Application Areas (square feet)

Slope %	0.5	0.7	1.0	1.5	2.0	3.0	4.0	
Length (ft)	300	375	425	525	600	750	800	
Width (ft)	20	6,000	7,500	8,500	10,500	12,000	15,000	17,000
	25	7,500	9,375	10,625	13,125	5,000	18,750	21,250
	30	9,000	11,250	12,750	15,750	18,000	22,500	25,500
	35	10,500	13,125	14,875	18,375	21,000	26,250	29,750
	40	12,000	15,000	17,000	21,000	24,000	30,000	34,000
	45	13,500	16,875	19,125	23,625	27,000	33,750	38,250
	50	15,000	18,750	21,250	26,350	30,000	37,500	42,500
	55	16,500	20,625	23,375	28,875	33,000	41,250	46,750
	60	18,000	22,500	25,500	31,500	36,000	45,000	51,000
	65	19,500	24,375	27,625	34,125	39,000	48,750	55,250
	70	21,000	26,250	29,750	36,750	42,000	52,500	59,500
	75	22,500	28,125	31,875	39,375	45,000	56,250	63,750
	80	24,000	30,000	34,000	42,000	48,000	60,000	68,000
85	25,500	31,875	36,125	44,625	51,000	63,750	72,250	
90	27,000	33,750	38,250	47,250	54,000	67,500	76,500	
95	28,500	35,625	40,375	49,875	57,000	71,250	80,750	
100	30,000	37,500	42,500	52,500	60,000	75,000	85,000	

Section 570.APPENDIX F

Recommended Effluent Transport Systems Designs

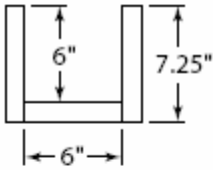
Type	Maximum Flow* Q _f (gpm)	Minimum Slope (%)	Design Velocity (fps)	Materials	Dimensions	Diagrams
Pipe	179	0.5	2	PVC	6" Dia.	
	332	0.4	2	PVC	8" Dia.	
Open Channel	224	0.33	2	Concrete Wood Asphalt Aluminum	6" X 6"	

* Mannings Equation with n = 0.013

Section 570.APPENDIX G

Graph for Determining Flow Rate Over Field Application Area

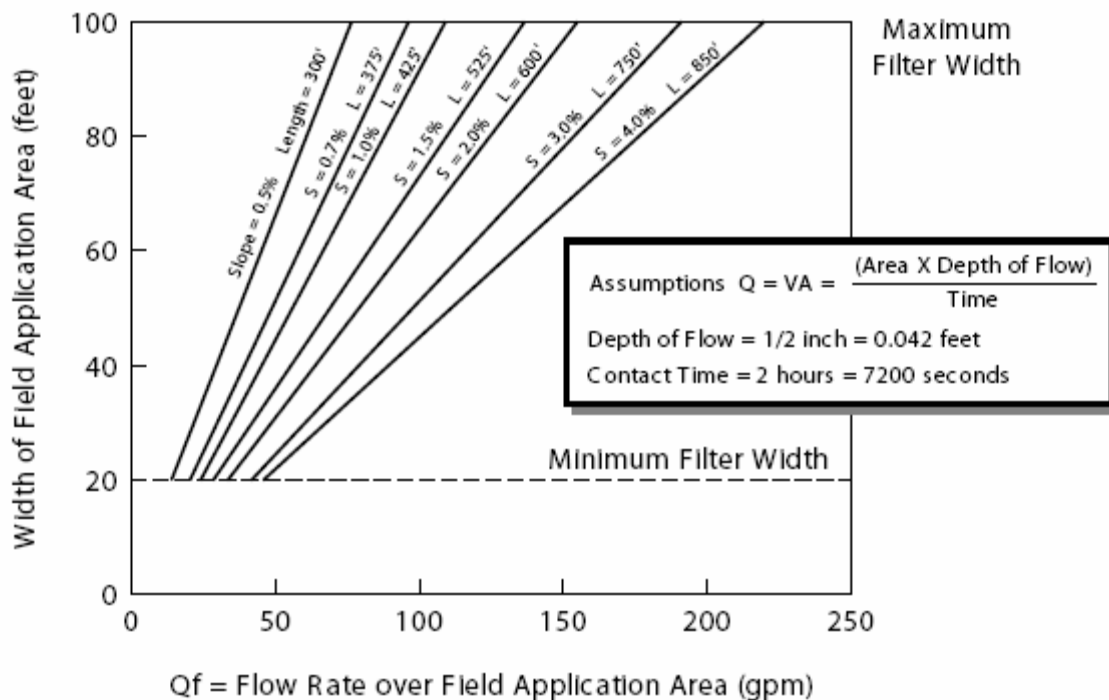

Section 570.APPENDIX H

Recommended Distribution Manifold Designs

Type ¹	Maximum Flow Q _r (gpm)	Slope	Initial Velocity (fps)	Dimensions	Materials ²	Weirs ³	Diagram
1/2 Pipe	150	level	1.3	8" dia.	PVC	30° V-notch	A
	225	level	1.3	10" dia.	PVC	30° V-notch	B
Box Trough	225	level	1.0	6" X 6"	2" X 8" dimension lumber	30° V-notch	C

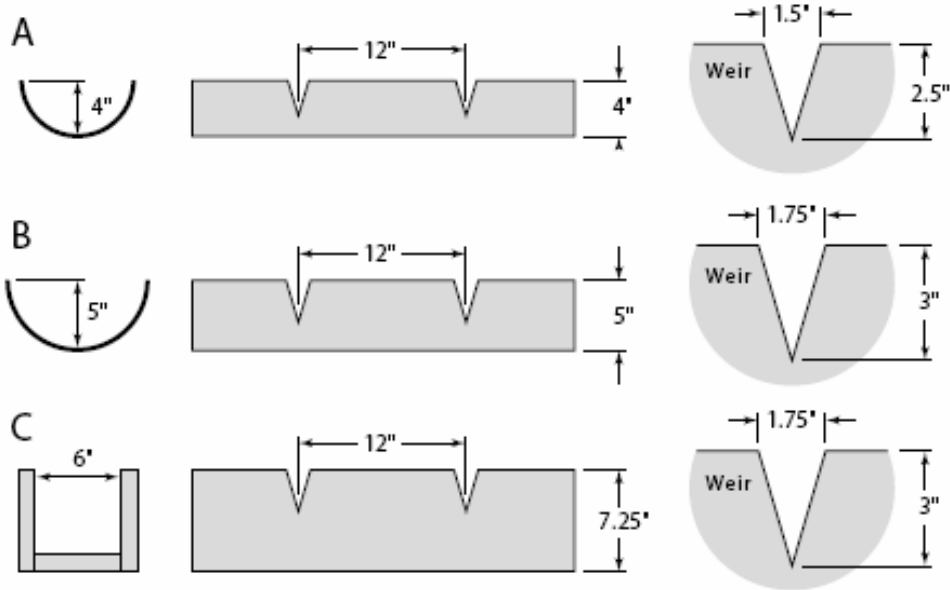

¹ Anchor with 1/8" thick wire staples spaced 5–8 feet apart

² Manning's roughness coefficient $n = 0.013$

³ One foot on center spacing; sharp crested weir on pipe, broad crested on box trough

Section 570.APPENDIX I

Recommended Junction Box Design

Cross-Section

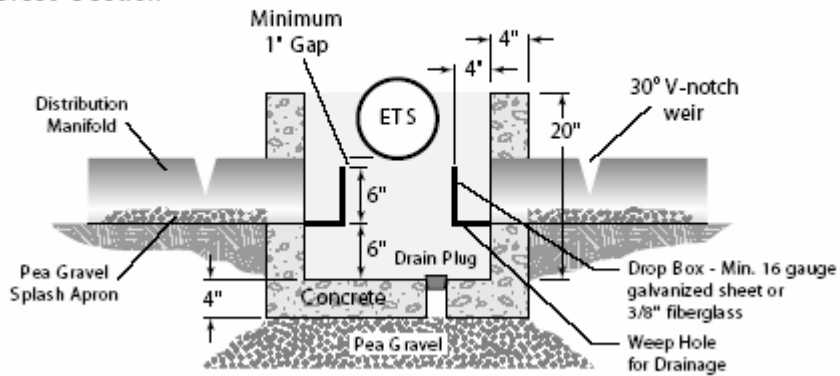

Top View

The top of the drop boxes must be at equal elevation. Adjustable slots on drop boxes may be used to compensate for frost heaving of junction box.

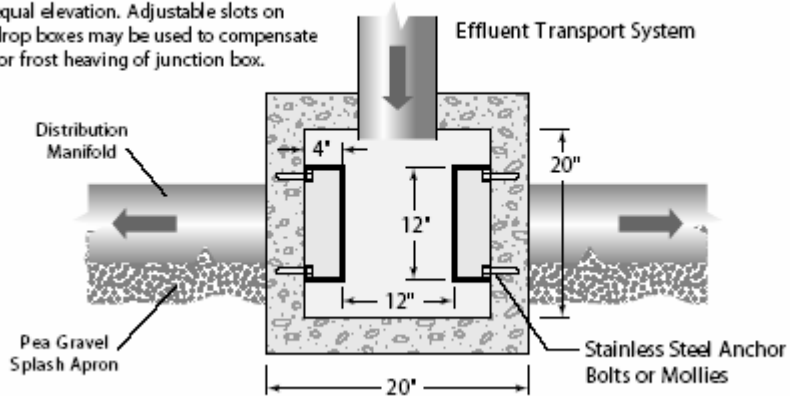

Section 570.APPENDIX J

Diagram of Settling Basin Components

Total Volume = $V_1 + V_2$
(cubic feet)

$$V_1 = 1/2 bhL_1$$

$$V_2 = \text{Total Volume} - V_1$$

$$\text{Total Length} = L_1 + L_2$$

Pick: $h = 2$ to 4 feet

$b = 8$ to 15 feet recommended

slope = 12 to 15 feet recommended

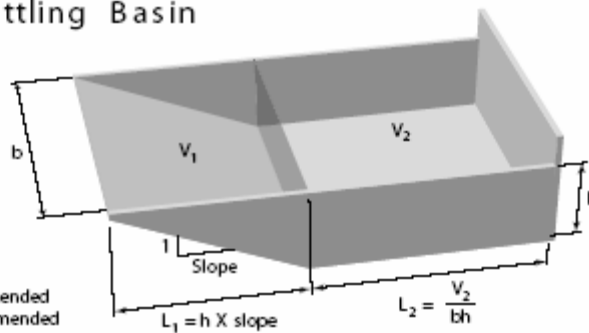

Settling Basin Dimensions (feet)

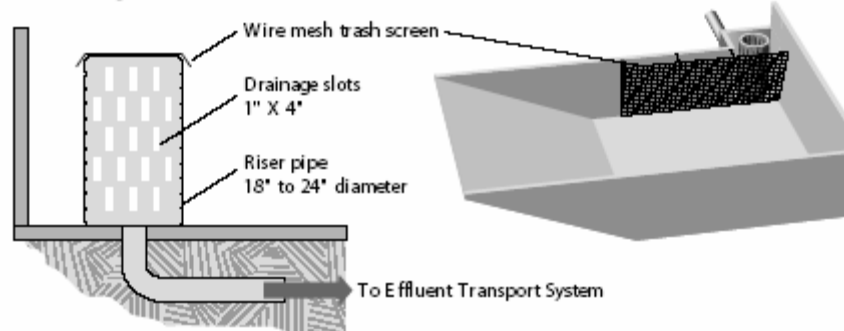

Section 570.APPENDIX K

Sample Design Problem

A livestock producer had 300 head of feeder cattle on a concrete feedlot (see Figure 1) and wanted to install a runoff field application system to control feedlot runoff which entered a nearby stream. The facility met the Conditions for System Utilization set forth in Section 570.202 and the runoff field application system was designed by following the procedure in Appendix A.

Site Specific Data

From Figure 1 and Appendix B:

Concrete Feedlot Area	20,038 sft. (0.46 acres)
Roof Area	4,792 sft. (0.11 acres)

All other drainage was diverted from the feedlot and field application area with gutters, curbs, and berms.

From the procedure in Appendix D, the slope of the field application area was 1.0%.

From the Soil Survey for the county the soil infiltration rate (SI) of the field application area was 2.0 inches/hour using the procedure in Appendix C (#3).

From Appendix B, runoff volume was calculated.

Roof 4,785 sft. x 0.1408 = 673.7 cft.

Feedlot 20,037 sft. x 0.0991 = 1985.7 cft.

Design Runoff Volume (VR) = 2660 cft.

From Appendix B, the total drainage area was calculated.

20,037 + 4,785 = 24,822 square feet

Settling Basin Design

The total settling basin volume was calculated as provided in Section 570.204.

$$24,822 \text{ sft.} \times \frac{4.5 \text{ cft.}}{100 \text{ sft.}} = 1117 \text{ cubic feet}$$

$$\underline{1117 \text{ cft.} \times 0.10 = 112 \text{ cubic feet}}$$

Total Volume = 1229 cubic feet

From Appendix I, the settling basin dimensions were calculated after choosing 3 feet settling basin height (h), 12 feet width (b), and 15:1 slope.

$$L_1 = 3 \times 15 = 45 \text{ feet}$$

$$V_1 = (1/2) (12 \times 3 \times 45) = 810 \text{ cft.}$$

$$V_2 = 1229 - 810 = 419 \text{ cft.}$$

$$L_2 = 419 / (12 \times 3) = 11 \text{ feet, 8 inches}$$

Round-off L_2 to 12 feet.

Foundation drainage tiles were not needed as the soil survey indicated the groundwater table did not rise above 5 ft. depth. A 24-inch diameter riser pipe was provided pursuant to Section 570.204 (5) and concrete was chosen as the settling basin construction material.

Field Application Area Design

The field application area was calculated using Section 570.204.

$$\text{FAA} = \frac{2660 \times 12}{(2 \times 2.0) - 1.69} = \frac{31,920}{231} = 13,818 \text{ sft. (minimum area needed)}$$

Appendix E was used to determine the dimensions of the field application area using the next larger sized area of 14,875 sft.

Slope	1.0%
Length	425 feet
Width	35 feet
FAA	14,875 sft. (0.34 acres)

Calculate Flow onto Field Application Area

The flow onto the field application area was determined using Appendix G as being approximately 40 gpm. A more accurate calculation was made as follows:

$$Q_f = (0.0026) \times \text{FAA}$$

$$Q_f = (0.0026) \times 14,875 \text{ sft.} = 38.7 \text{ gpm}$$

Effluent Transport System Design

A pipe was chosen to transport the settling basin effluent to the distribution manifold and was designed using Appendix F at the 179 gpm criteria (since this pipe design could handle 38.7 gpm).

Slope 0.5 %
 PVC non-perforated pipe
 Diameter of pipe - 6 inches

Junction Box Design

A junction box was constructed to the specifications provided in Appendix H.

Adjustable slots were included in the drop boxes to compensate for frost heaving of the junction box in the future.

Distribution Manifold Design

The distribution manifolds were designed using the 1/2 Pipe criteria at 150 gpm as provided in Appendix H.

$$\text{Length of each manifold} = \frac{35 \text{ feet} - 2 \text{ feet}}{2} = 16.5 \text{ ft.}$$

An 8-inch diameter PVC pipe (17 feet long) was purchased and cut in half down the pipe length to provide 2 manifolds each 4-inches deep. Each manifold had 6 inches removed to provide the required length of 16.5 feet.

Tin snips were used to cut V-notch weirs 12 inches apart on center on one side of each manifold with each notch cut 1.5 inches wide and 2.5 inches deep.

The two distribution manifolds were placed in the previously installed junction box (the junction box was located in the center of the field application area width). Caps were provided over the outside end of each distribution manifold and 1/8 - inch wire staples were used to anchor each manifold at 5 foot spacings.

A 1-foot wide pea gravel splash apron was provided below the V-notch weirs over the length of each manifold.

Figure 1: Sample Design Problem

